

AZEV678

40 AMP 2 POLES POWER RELAY WITH MONITORING

FEATURES

- 40 Amp /480 VAC switching capability
- Dual NO load contacts plus isolated NC monitor contact for welding monitoring
- Withstands up to 1.85kA short circuit current
- Electrical rating according to IEC61851-1: CC2/50k cycles
- Load contact gap: ≥ 3 mm
- Dielectric strength : 5 kV_{RMS}, between contacts and coil
- UL class F insulation
- UL / CUR E365652
- TÜV B088793 0020
- CQC 22002356459



CONTACTS

Arrangement load contact monitor contact	2PST-NO(2 Form A) SPST-NC(1 Form B) coupled to load contacts
Ratings (max.) Load contacts switched power switched current continuous current switched voltage monitor contact Max. switched current	(resistive load) 19200 VA 40 A 40 A 480VAC 100mA, 12VDC
UL/CUR/TÜV/CQC Approval ratings load contact	40A at 480VAC, resistive, 85°C, 6k cycles 35A at 400VAC, resistive, 85°C, 50k cycles 10A make, 40A carry, 10A break, At 480VAC, 85°C, resistive, 50k cycles
monitor contact Minimum load	10mA at 12VDC, 85°C, 50k cycles 10mA, 5VDC Note: Approvals with open vent hole only.
Contact material load contact monitor contact	AgSnO ₂ AgNi (gold plated)
Contact gap load contact monitor contact	≥ 3 mm ≥ 0.7 mm
Contact resistance initial	load contact: ≤ 10 m Ω (6VDC 20A) monitor contact: ≤ 100 m Ω (6VDC 1A)

COIL

Nominal coil DC voltages *	6, 9, 12, 24, 48
Dropout voltage	> 5% of nominal coil voltage
Holding voltage *	(35% ~80%) of nominal coil voltage (@23°C) (40% ~65%) of nominal coil voltage (@85°C)
Coil power nominal holding power at pickup voltage	(at 23 °C) 2.6 W 416 mW 1463 mW
Temperature Rise	70 K @ max. at holding voltage, 85°C
Max. temperature	Class F insulation - 155°C (311°F)

* Notes1: To avoid overheating and burning, the voltage continuously applied to the coil must be the holding voltage, which shall be applied after 500ms from the applied nominal coil voltage.

GENERAL DATA

Life Expectancy mechanical electrical	(minimum operations) 1 x 10 ⁵ See approval ratings
Operate Time	30 ms (max.) at nominal coil voltage
Release Time	10 ms (max.) at nominal coil voltage, without coil suppression
Dielectric Strength (Initial) between open load contacts between load contacts sets between coil and load contacts between load and monitor contacts between open monitor contacts between coil and monitor contacts	(at sea level for 1 min.) 3000 V _{RMS} 3000 V _{RMS} 5000 V _{RMS} 5000 V _{RMS} 1000 V _{RMS} 1000 V _{RMS}
Short circuit capacity Based on requirements of EN/IEC 62955:2018	Test sequence E: [9.11.2.3 a)]: 250VAC, I _p =1.85kA, I ² t =4.5kA ² s (I _n ≤32A, I _c =3kA) [9.11.2.2)]: 250VAC, I _m =500A Test sequence F : [9.11.2.3 b)]: 250VAC, I _m =500A [9.11.2.3 c)]: 250VAC, I _p =1.85kA, I ² t =4.5kA ² s (I _n ≤32A, I _c =3kA)
Surge Voltage @1.2/50 μ s	10kV coil to load contacts 6kV between load contacts 8kV monitor contacts to load contacts
Insulation Resistance	1000 M Ω (min.) at 23°C, 500 VDC, 50% RH
Temperature Range operating	(at holding coil voltage) -40°C (-40°F) to 85°C (185°F)
Vibration resistance	0.062" (1.5 mm) DA at 10–55 Hz
Shock	10 g
Enclosure protection category material group flammability	RT II, flux proof IIla UL94 V-0
Terminals	Tinned copper alloy, P. C.
Soldering preheating soldering	(referring IEC 61760-1 wave soldering) 120°C (248°F) / ≤ 120 s 260 ± 5 °C (500 ± 9 °F) / $\leq 2 \times 5$ s
Dimensions length width height	36.5 mm (1.41") 33.8mm (1.33") 41.5 mm (1.63")
Weight	85 grams (approx.)
Compliance	RoHS, REACH
Packing unit in pcs	10 per plastic tube/ 150 per carton box

ZETTLER

AZEV678

COIL VOLTAGE SPECIFICATIONS

Nominal Coil VDC	Must Operate VDC ²⁾	Min. Holding VDC ³⁾	Max. Cont. VDC ⁴⁾	Resistance Ohm \pm 10%
6	4.5	2.4	6.6	13.9
9	6.7	3.6	9.9	31.2
12	9.0	4.8	13.2	55.4
24	18.0	9.6	26.4	221.5
48	36.0	19.2	52.8	886.2

Notes2:

- 1) All values at 23°C, upright position, terminals downward.
- 2) Relay may pull in with less than "Must Operate" value.
- 3) After 500ms rated voltage.
- 4) Continuous time is less than 60 seconds
- 5) To avoid overheating at elevated ambient temperatures, operate the coil at holding voltage after applying the full nominal coil voltage for \geq 500 milliseconds.

ORDERING DATA

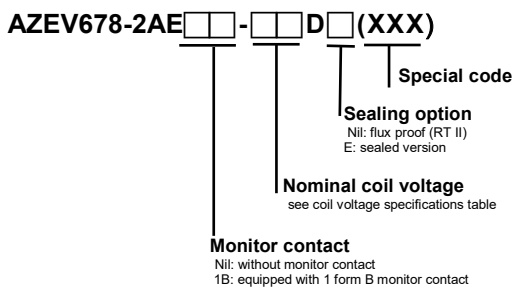

Note: For Ag plating contact (main load), add P after date code.

Example ordering data

AZEV678-2AE1B-12D With monitor contact

IEC 62752 / IEC 62955 Short Circuit Withstand

Compliance with IEC 62752, IEC 62955 or similar standards for short circuit withstand is a function of both relay design and PCB layout. ZETTLER's relay design and applications engineering teams have developed an application note that contains important design suggestions to optimize the performance of the relay with respect to its short circuit current withstand capability.

In addition, as the overall performance depends on multiple factors such as part arrangement and trace routing, compliance cannot be generically guaranteed by ZETTLER. We strongly encourage customers to conduct their own short circuit tests in accordance with IEC 62752, IEC 62955 or similar standards in the context of their individual application design.

PC BOARD LAYOUT WIRING DIAGRAMS

Viewed towards terminals. Note: Pins 11 and 12 are omitted in

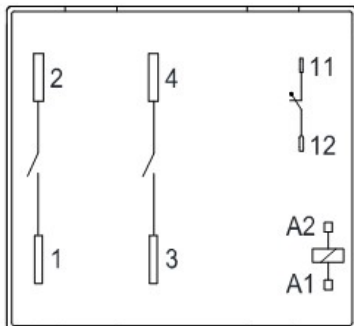

MECHANICAL DATA

Dimensions in mm. Tolerance: \pm 0.3mm if not stated otherwise.

Notes: 1. Pin dimensions for reference only and given without tin coating.

2. Pins 11 and 12 are omitted in versions without 1 Form B monitor contact.

3. With sealed versions the vent hole is sealed by epoxy and the auxiliary vent hole

must be cut open to achieve the specified performance and service life.

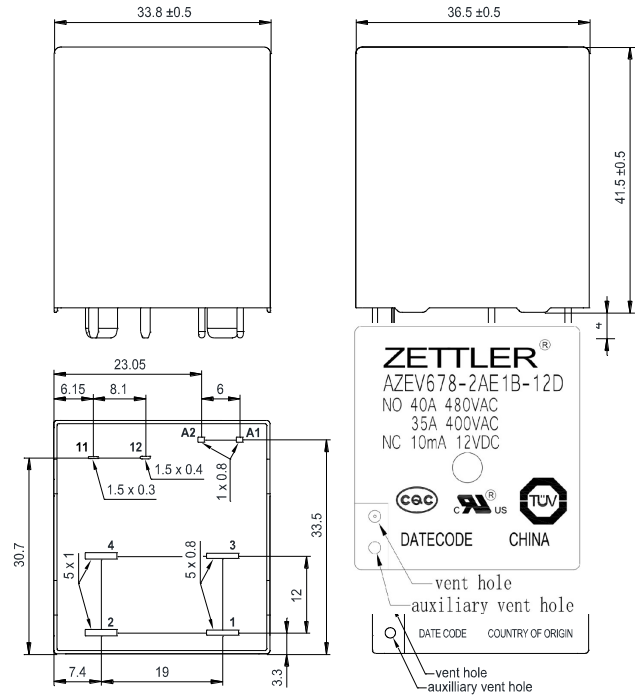

PC BOARD LAYOUT

Dimensions in mm. Dimensions in mm. Viewed towards terminals.

Note: Pins 11 and 12 are omitted in versions without 1 Form B monitor contact.

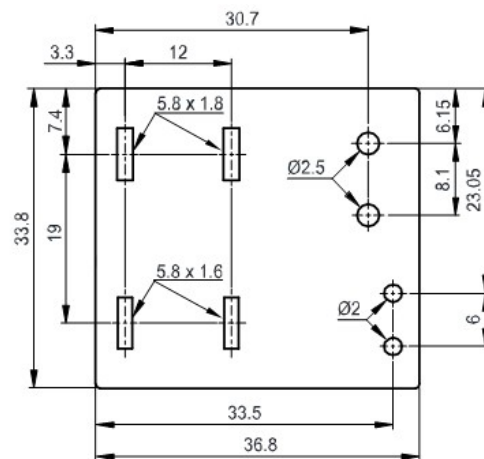

NOTES

General

1. All values in this datasheet are at reference temperature of 23°C (73°F) unless stated otherwise.
2. Evaluate the component's performance and operating conditions under the worst-case conditions of the actual application.
3. The datasheet and the component's specifications are subject to change without notice.

Storage, handling, and environmental guidelines

4. Relays are electromechanical components that are sensitive to shock. The relay's adjustment can be affected if the relay is subjected to excessive shock or excessive pressure is applied to the relay case. Relays which have been dropped must no longer be used.
5. Substances containing silicone or phosphorus must be avoided in the vicinity to the relay. Outgassing from these substances can penetrate the relay and adhere on the contacts. Deposits of these substances may act as insulators and adversely affect the contact resistance. Silicone can be found e.g. in gaskets, lubricants or filling materials, phosphorus can be found e.g. as a flame retardant in plastics.
6. Prevent relays from atmospheres containing corrosive gases. Corrosion of internal structures and contacts leads to malfunction and shortens the component's service life.
7. Prevent non-sealed relays and relays with opened vent hole from atmospheres subject to dust. Dust particles may enter the case and get stuck between the contacts, causing the contact circuits to fail.
8. Do not use these relays in environments with explosive or flammable gases. Electrical arcing at the contacts could ignite these gases and cause fire.
9. For automated dual wave soldering process we recommend preheating with 120°C (248°F) for max. 120 seconds and a soldering temperature of 260 ±5°C (500 ±9°F) for max. 10 seconds soldering time (max. 5 seconds per wave). For manual soldering we recommend 350°C (662°F) max. temperature for max. 5 seconds. During the soldering process, no force may be exerted on the relay terminals.
10. Non-sealed relays must not be washed, immersion cleaned or conformal coated as substances may enter the case and cause corrosion or seizure of mechanical parts.
11. With sealed versions of this relay type, the auxiliary vent hole must be cut open after washing or conformal coating to achieve the specified performance and service life. Care must be taken to ensure no particles get into the relay as a result of the cutting process.
12. Avoid high frequency or ultrasonic vibrations on the relays as these can cause contact welding and misalignment or destruction of internal structures.
13. During operation, storage and transport, ambient temperature should be within the specified operating temperature range. Humidity should be in the range of 5% to 85% RH. Icing and condensation must be avoided. Relays stored for an extended period of time may show initially increased contact resistance values due to chemical effects such as oxidation.

Design guidelines

14. The relay may pull in and operate with less than the specified *must operate* voltage value.
15. The coil's *must operate* and *min. holding* voltages, the coil's *ohmic resistance* and the relay's *operate time* depend on the temperature of the coil. The specified values are given for a coil temperature of 23°C and increase by approx. 0.39% per Kelvin of temperature rise. This circumstance must be considered, especially during operation with high load currents and elevated ambient temperature.
16. At elevated ambient temperatures, after applying the rated nominal coil voltage for ≥ 200 milliseconds, the coil energization must be reduced to a holding level in order to reduce thermal stress and prevent the coil from overheating.
17. Coil suppression circuits such as diodes, etc. in parallel to the coil will lengthen the release time. We recommend using suppression circuits with a breakdown voltage of approx. 2 times the nominal coil voltage in order to achieve a quick release time.
18. For short-circuit performance according IEC 62955 or IEC 62752, coil suppression circuits with a breakdown voltage of ≥1.5 times the nominal coil voltage must be used. Using rectifier diodes or similar in parallel to the coil is not appropriate.
19. When using PWM coil control, use a fast-switching recirculation diode in parallel with the coil to keep the coil current during pulse pauses. To achieve the IEC 62955 or IEC 62752 required short-circuit performance, when de-energizing the coil, the diode must be eliminated from the circuit to get a fast decay of coil current and a short release time. As PWM frequency we recommend ≥ 15 kHz in order to avoid audible noise from magnetostriction. To reduce EMI effects, we recommend to apply the PWM to the coil's inner layer terminal (A2) and have the outer layer terminal (A1) connected to ground or the supply rail.
20. Contact resistance is a function of load current, dwell time and wear level of the contacts. Immediately after closing the contacts, or if tested with low current only, the contact resistance will show a relatively high value. A low level steady state contact resistance is reached at higher current after a certain time in thermal equilibrium.
21. The relay dissipates heat form power losses through its load terminals. Provide sufficient cross section and area of the PCB traces so that they can act as heat spreader.
22. For PCBs with multiple relays, do not place the components directly next to each other. We suggest providing a mounting distance of minimum 10 mm to allow for better cooling.
23. A minimum load of 10 mA / 5 V / 50 mW is recommended for the gold plated monitor contact to ensure a reliable and stable electrical connection.
24. The relay's NC mirror contact bounces when switching. For evaluation of its signal, suitable debouncing measures must be taken to get a reliable signal.

AZEV678

DISCLAIMER

This product specification is to be used in conjunction with the application notes which can be downloaded from the regional ZETTLER relay websites. The specification provides an overview of the most significant part features. Any individual applications and operating conditions are not taken into consideration. It is recommended to test the product under application conditions. Responsibility for the application remains with the customer. Proper operation and service life cannot be guaranteed if the part is operated outside the specified limits.

ZETTLER GROUP

Building on a foundation of more than a century of expertise in German precision engineering, ZETTLER Group is a world-class enterprise, engaged in the design, manufacturing, sales and distribution of electronic components. Our industry leadership is based on a unique combination of engineering competence and global scale.

For more information on other ZETTLER Group companies, please visit zettler-group.com. For support on this product or other ZETTLER relays, please visit one of the group sites below.

SITES FOR ZETTLER RELAYS

NORTH AMERICA

American Zettler, Inc.
www.azettler.com
sales@azettler.com

EUROPE

Zettler Electronics, GmbH
www.zettlerelectronics.com
office@zettlerelectronics.com

Zettler Electronics, Poland
www.zettlerelectronics.pl
office@zettlerelectronics.pl

CHINA

Zettler Group, China
www.zettlercn.com
relay@zettlercn.com

ASIA PACIFIC

Zettler Electronics (HK) Ltd.
www.zettlerhk.com
sales@zettlerhk.com

